

1-AVC See-Through Air Vent

For Pressures to 10 bar or Specific Gravity Down to 0,80

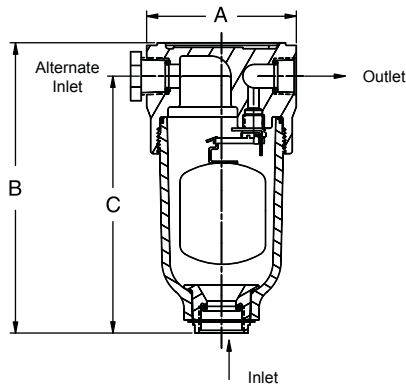

1-AVC



A See-Through Body – So You'll Know When It's Working

Now, you can literally see what you've been missing – the early warning signs of a system problem. Since you'll know the operating condition of the air vent, you won't have to waste time and money scheduling maintenance that isn't needed. In other words, you will be able to react to a condition before it becomes a problem.

A simple ball float mechanism requiring no electricity to operate, the new Armstrong 1-AVC discharges automatically only when air/gas are present. That means no liquid loss as with manual venting.

An Inside Look

See-through body means you can observe changing conditions as they occur. See a problem in the making – instead of having to deal with it after the fact.

Efficient Operation

Simple ball float mechanism discharges only when air is present so it doesn't waste liquid.

Positive Seating

Free-floating valve mechanism assures positive seating so it prevents liquid loss. There are no fixed pivots to wear or create friction, and wear points are heavily reinforced for long life.

Reduced Maintenance

Stainless steel internals mean corrosion resistance and reduced maintenance.

Corrosion Resistance

Long-lasting polysulfone body and reinforced nylon cap resist corrosion and provide long, trouble-free service life.

Compare... and Save the Difference

Seeing is really believing – especially when you compare the Armstrong see-through air vent with manual venting. Measure the differences in the time and money you can save with a more efficient, easier-to-maintain system. For more information or technical assistance, contact your local Armstrong Representative.

Note: The Armstrong 1-AVC should not be used in an environment where there are high levels of ketones or chlorinated or aromatic hydrocarbons.

Table AV-338-1. 1-AVC List of Materials

Name of Part	Material
Cap	Reinforced Nylon
Body	Polysulfone*
O-Rings (Body Cap and Fitting)	Nitrile Elastome Compound
Float Lever and Screws	Stainless Steel
Valve & Seat	Stainless Steel
Fitting & Pipe Plug	Reinforced Nylon
Retainer Ring	Zinc Plated Steel

* UV sensitive.

Table AV-338-2. 1-AVC Physical Data

	mm
Inlet Connection	15 – 20
Outlet Connection	15
"A" Face-to-Face	89
"B" Height	171
"C" Bottom to ϕ	152
Maximum Allowable Pressure (Vessel Design)	10 bar @ 65°C
Maximum Operating Pressure	10 bar
Specific Gravity Range	1,00 to 0,80
Weight in kg (screwed)	0,45

All sizes comply with the article 3.3 of the PED (97/23/EC).

Table AV-338-3. 1-AVC Capacity

Differential Pressure	Orifice size (in)	m ³ /h
bar		
1,0	1/8"	7,3
2,0		11,0
3,5		16,1
5,0		22,2
7,0		28,7
8,5		34,8
10,0		41,1

Note: Discharge of air through an orifice in m³/h at a standard atmospheric pressure of 1 bar(a) and 21°C.

All dimensions and weights are approximate. Use certified print for exact dimensions. Design and materials are subject to change without notice.