



# ARMSTRONG STEAM FILTERS

(ASF)





---

## Contents

ASF Steam Filter Housings . . . . .	3 - 6
Specifications . . . . .	3
Dimensions . . . . .	4 - 6
ASFS Sanitary Steam Filter Housings . . . . .	7 - 9
Specifications . . . . .	7
Dimensions . . . . .	8 - 9
Filter Elements - Sintered . . . . .	10 -12
Features & Benefits. . . . .	10
Applications . . . . .	10
Product Specifications . . . . .	11
Filtration Surface Area . . . . .	11
Materials . . . . .	11
Dimensions . . . . .	12
Sterile, Steam And Liquid Filtration . . . . .	13
Specifications & Dimensions. . . . .	14
Sizing and Selection Guidelines . . . . .	15
Regeneration/Cleaning . . . . .	15
Capacities for Steam . . . . .	16
Limited Warranty and Remedy . . . . .	17

# ASF Steam Filter Housings



## Steam Filter Housings

### Stainless Steel Steam Filter Housings

Armstrong ASF housings are designed for filtering of steam. They are equipped with NPT thread or flange connections depending on size and have an electro-polished or bead-blast surface finish. ASF housings are designed to yield low differential pressure at high flow rates.

ASF housings are available in 18 different sizes with a capacity range from 100 to 17,100 lbs/hr at 50 psig. Optional connections are also available to adapt the filter to your specific requirements. Standard housings utilize Armstrong filter elements with 2-inch, double o-ring, plug-in connections.

### Specifications

Materials	
Filter Housing	304 SS 316L SS (on request)
Seating Nut	304 stainless steel
Plug	304SS/PTFE gasket
Housing Gasket	EPDM 291 (up to 356°F) Fluoraz®* (up to 392°F)

\*Fluoraz is a registered trademark of Greene, Tweed & Co.

Design Pressure/Temperature	
FNPT Housing (ASF-H4 1/4 NPT - 3 NPT L)	200 psig @ 392°F
FNPT Housing (ASF-H4 3 NPT H)	174 psig @ 392°F
ANSI Flange Housing (ASF-H4 4 FWL - 8 FWH)*	150 psig @ 392°F

\* ANSI Flanged housings (4" - 8") are ASME code stamped

Surface Finish	
Inner	
ASF-H4 1/4 NPT - 3 NPT	Pickled and passivated Ra 63
ASF-H4 4 FWL - 8 FWH	Bead blast
Outer	
ASF-H4 1/4 NPT - 3 NPT	Pickled, passivated, and polished Ra 63
ASF-H4 4 FWL - 8 FWH	Bead blast

Connection Types	
NPT thread connection (standard for 1/4" - 3")	
ANSI flange (standard for 4" - 8"; optional for 1/4" - 3")	
Other connections and bigger housings are available on request	



ASF Housing

Designs, materials, weights and performance ratings are approximate and subject to change without notice. Visit [armstronginternational.com](http://armstronginternational.com) for up-to-date information.

## Dimensions

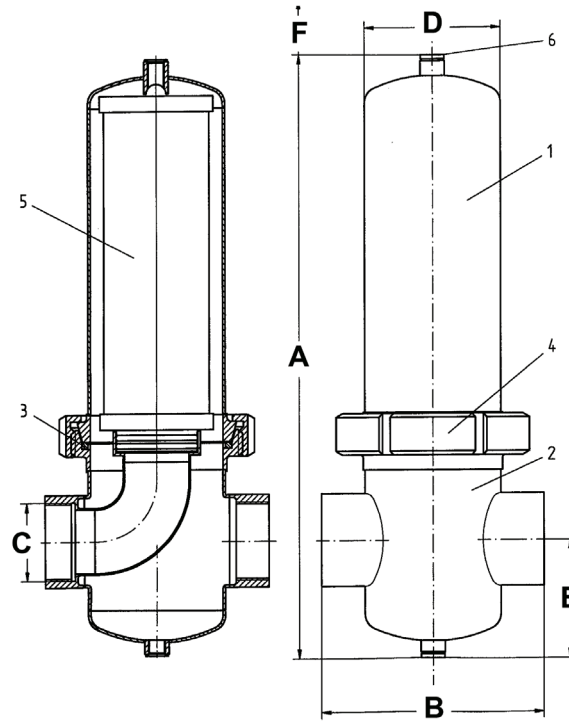

**Threaded Connection**

Callout	Quantity	Description
1	1	upper housing bowl
2	1	lower housing bowl
3	1	housing gasket

Callout	Quantity	Description
4	1	sealing nut
5	1	filter element
6	2	plug

Model Number	Connection Size (inch)	Volume (gal)	Weight* (lb)	Dimensions (inches)						Element Size
				A	B (± .125)	C w/NPT thread connection	D	E	F	
ASF-H4 1/4	1/4	0.1	4	8.2	4.1	0.25	3	2	4	03/10
ASF-H4 3/8	3/8	0.2	4	9.5	4.25	0.375	3	2	5	04/10
ASF-H4 1/2	1/2	0.2	4	9.5	4.25	0.50	3	2	5	04/20
ASF-H4 3/4	3/4	0.2	4	10.5	4.9	0.75	3	2.3	6	05/20
ASF-H4 1	1	0.3	6	11.5	4.9	1.00	3	2.6	6	05/25
ASF-H4 1-1/4	1-1/4	0.3	7	13.5	5.5	1.25	3	2.6	8	07/25
ASF-H4 1-1/2	1-1/2	0.6	9	15	6.7	1.50	4	3.5	8	07/30
ASF-H4 2 L**	2	0.9	11	18	6.7	2.00	4	3.5	11	10/30
ASF-H4 2 H**	2	1.1	12	23	6.7	2.00	4	3.5	18	15/30
ASF-H4 2-1/2	2-1/2	2.1	20	29	8.5	2.50	5	4.5	23	20/30
ASF-H4 3 L**	3	2.9	24	39	8.5	3.00	5	4.5	33	30/30
ASF-H4 3 H**	3	4.4	36	40	9.5	3.00	6	4.5	33	30/50

\* Without filter element

\*\* L designates low capacity and H designates high capacity

NOTE: Drain Connection = 1/4" NPT, Vent Connection = 1/4" BSPP

# ASF Steam Filter Housings



## Dimensions

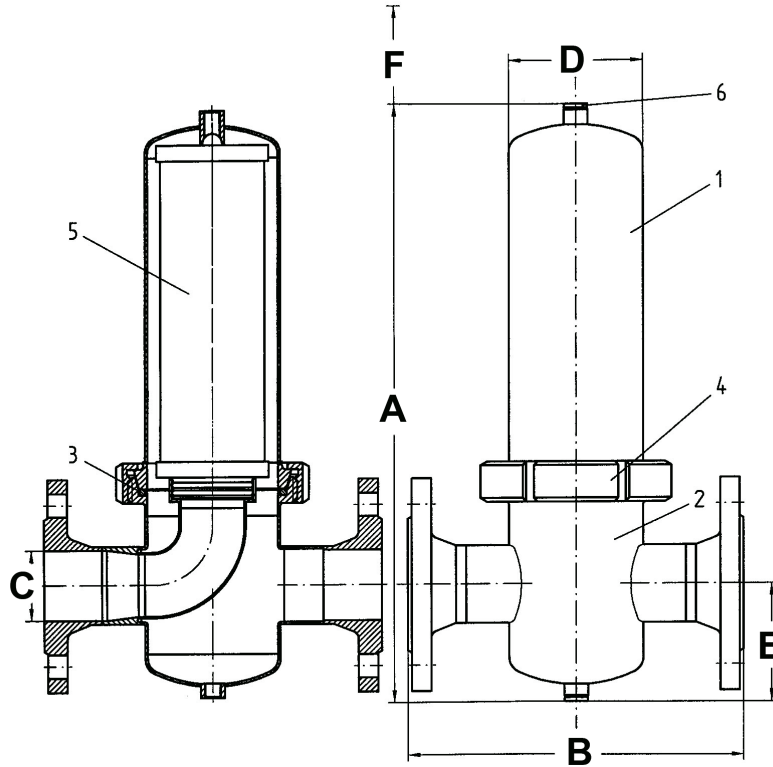

Flange Connection ANSI Class 150

Callout	Quantity	Description
1	1	upper housing bowl
2	1	lower housing bowl
3	1	housing gasket

Callout	Quantity	Description
4	1	sealing nut
5	1	filter element
6	2	plug

Model Number	Connection Size (inch)	Volume (gal)	Weight* (lb)	Dimensions (inches)						Element Size
				A	B (± .125)	C**	D	E	F	
ASF-H4 1/4 FW	1/4	0.1	6	8.5	8.00	0.50	3	2	4	03/10
ASF-H4 3/8 FW	3/8	0.2	6	9.5	8.00	0.50	3	2	5	04/10
ASF-H4 1/2 FW	1/2	0.2	7	9.5	8.00	0.50	3	2	5	04/20
ASF-H4 3/4 FW	3/4	0.2	9	10.5	9.00	0.75	3	2	6	05/20
ASF-H4 1 FW	1	0.3	11	11.5	9.69	1.00	3	3	6	05/25
ASF-H4 1-1/4 FW	1-1/4	0.3	14	13.5	10.00	1.25	3	3	8	07/25
ASF-H4 1-1/2 FW	1-1/2	0.6	18	15.2	11.58	1.50	4	4	8	07/30
ASF-H4 2 FW L***	2	0.9	22	18.1	11.69	2.00	4	4	11	10/30
ASF-H4 2 FW H***	2	1.1	23	23.1	11.69	2.00	4	4	18	15/30
ASF-H4 2-1/2 FW	2-1/2	2.1	33	28.8	13.39	2.50	5	4	23	20/30
ASF-H4 3 FW L***	3	2.9	40	39.0	13.39	3.00	5	4	33	30/30
ASF-H4 3 FW H***	3	4.4	52	40.4	14.96	3.00	6	5	33	30/50

\* Without filter element

\*\* ANSI B16.5 Class 150. Sizes 1/4" - 3" are not ASME code stamped

\*\*\* L designates low capacity and H designates high capacity

NOTE: Drain Connection = 1/4" NPT, Vent Connection = 1/4" BSPP

Designs, materials, weights and performance ratings are approximate and subject to change without notice. Visit [armstronginternational.com](http://armstronginternational.com) for up-to-date information.

## Dimensions

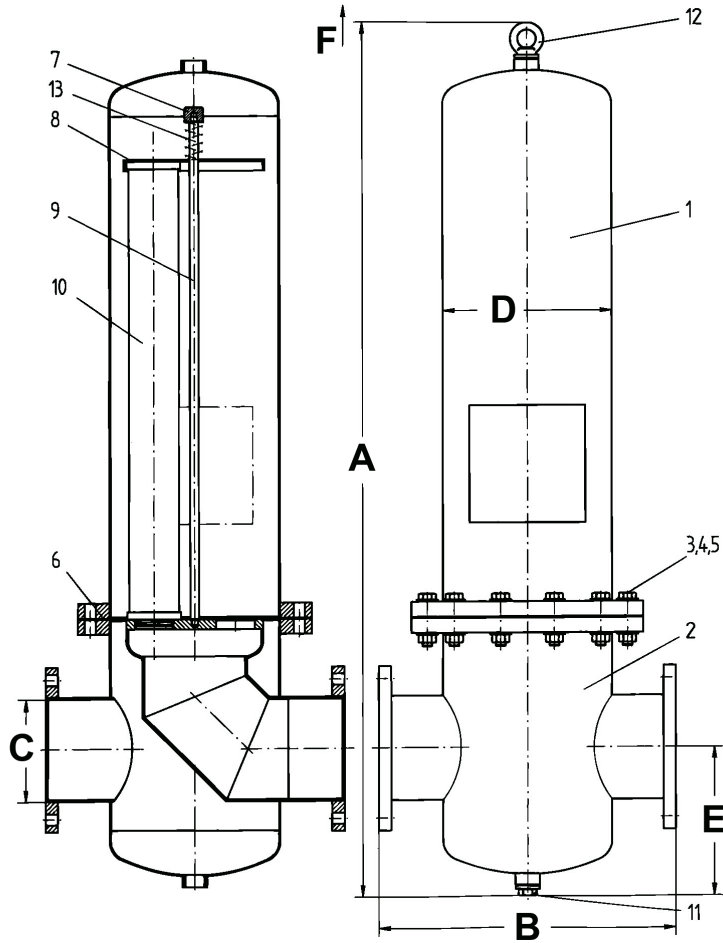

Position	Description
1	upper housing bowl
2	lower housing bowl
3	hexagon bolt
4	washer
5	nut
6	gasket
7	bracket bolt
8	bracket plate
9	tie rod
10	filter element
11	plug
12	lifting eye bolts
13	spring

**Flange Connection ANSI Class 150**

Model Number	Connection Size (inch)	Volume (gal)	Weight* (lb)	Dimensions (inches)						Element Size
				A	B (± .125)	C**	D	E	F	
ASF-H4 4 FW L***	4	9.5	140	36.7	16.14	4	8.6	7.3	23	3 x 20/30
ASF-H4 4 FW H***	4	11.9	183	47.0	16.14	4	8.6	7.3	33	3 x 30/30
ASF-H4 6 FW L***	6	20.3	225	51.3	18.90	6	10.8	8.2	33	4 x 30/30
ASF-H4 6 FW H***	6	29.1	338	54.8	21.26	6	12.8	8.8	33	6 x 30/30
ASF-H4 8 FW L***	8	50.2	628	58.8	26.00	8	16.0	12.3	33	8 x 30/30
ASF-H4 8 FW H***	8	50.2	628	58.8	26.00	8	16.0	12.3	33	10 x 30/30

\* Without filter element

\*\* ANSI B16.5 Class 150. Sizes 4" - 8" are ASME code stamped

\*\*\* L designates low capacity and H designates high capacity

NOTE: Drain Connection = 1/2" NPT, Vent Connection = 1/2" BSPP

# ASFS Sanitary Filter Housings



## Stainless Steel Filter Housings For Sanitary Applications

The Armstrong ASFS housings are designed for filtering of steam in the pharmaceutical, biotechnology, chemical, electronic, food and beverage industries.

ASFS housings are equipped with sanitary Tri-Clamp and flange connections, and have an electropolished surface finish of Ra 32. The top vent is sealed with a pharma plug while the bottom condensate drain is equipped with a pharma valve. ASFS housings are designed to yield low differential pressures at high flow rates.

Available in 12 different sizes with a capacity range for steam from 100 to 17,100 lbs/hr at 50 psig. Optional connections are also available to adapt the filter to your specific requirements. Standard housings utilize Armstrong filter elements with 2-inch, double o-ring, plug-in connections.



## Specifications

Materials	
Filter Housing	316L stainless steel
Clamp	304 stainless steel
Pharma Plug	316 stainless steel
Pharma Valve	316 stainless steel
Housing Gasket	EPDM 291 (up to 356°F) Fluoraz® (up to 392°F)

Design Pressure/Temperature	
Tri-Clamp Housing (ASF-HS 1/2 Tri - 3 Tri)	200 psig @ 392°F
ANSI Flange Housing (ASF-HS 4FW - 8FW)	150 psig @ 392°F

3-A Sanitary Certified	
ASF-H4 1/2 Tri - 3 Tri	3-A stamped

Surface Finish
Etched, passivated, and electropolished to Ra32

Connection Types
Tri-Clamp (standard for 1/2" - 3")
ANSI flange (standard for 4" - 8"; optional up to 3")
Other connections and bigger housings are available on request

Designs, materials, weights and performance ratings are approximate and subject to change without notice. Visit [armstronginternational.com](http://armstronginternational.com) for up-to-date information.

## Dimensions

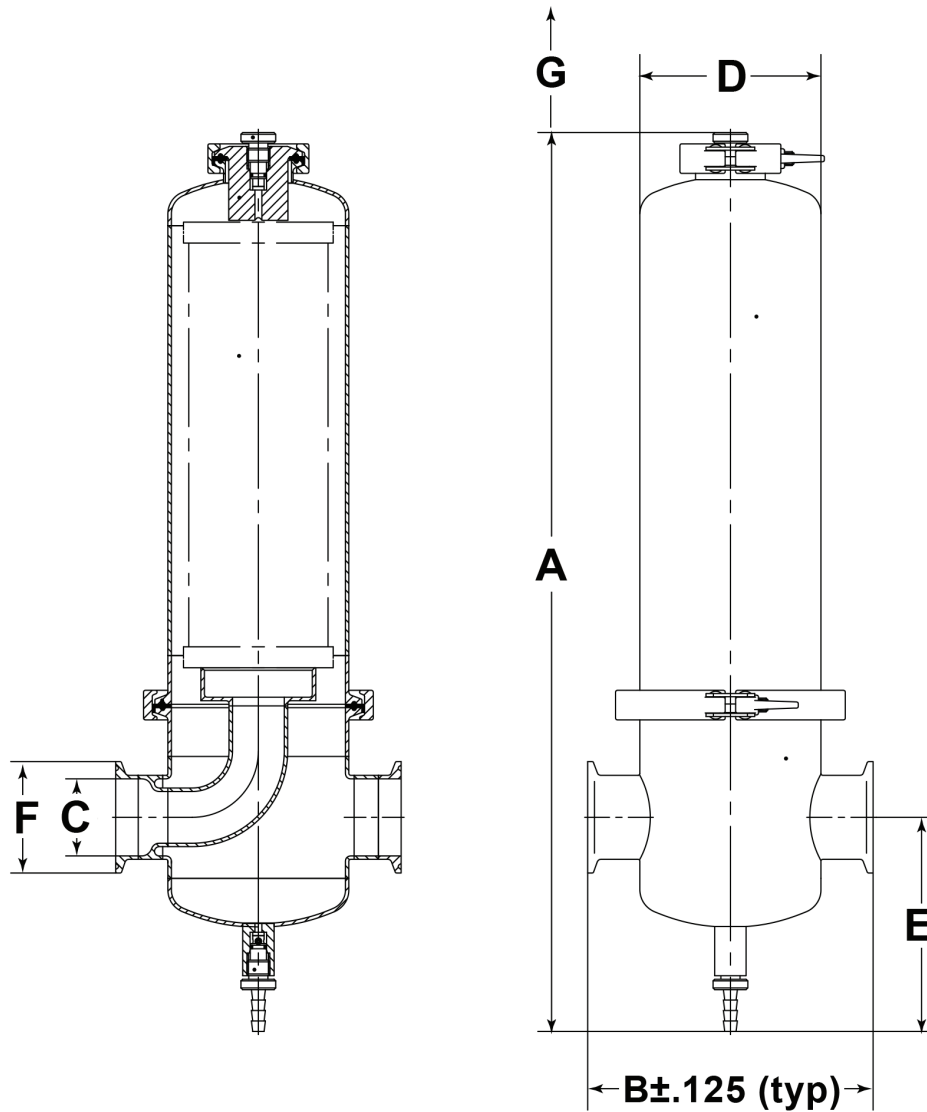

**Tri-Clamp Connection**

Model Number	Connection Size (inch)	Volume (gal)	Weight* (lb)	Dimensions (inches)							Element Size
				A	B	∅C	∅D	E	∅F	G	
ASF-HS 1/2 Tri L**	1/2	0.16	3.3	10.50	4.72	0.50	2.76	3.76	0.98	5.9	03/10
ASF-HS 1/2 Tri H**	1/2	0.21	3.8	12.54	4.72	0.50	2.76	3.76	0.98	8.0	05/20
ASF-HS 1 Tri	1	0.50	5.0	14.90	6.40	1.00	4.10	4.84	2.00	9.0	05/30
ASF-HS 2 Tri	2	0.90	6.5	19.90	6.50	2.00	4.10	4.84	2.52	14.2	10/30
ASF-HS 2-1/2 Tri	2-1/2	1.43	10.0	31.00	8.14	2.50	4.10	5.43	2.96	24.0	20/30
ASF-HS 3 Tri	3	1.95	12.5	41.00	8.14	3.00	4.10	5.43	3.60	33.9	30/30

\* Without filter element

\*\* L designates low capacity and H designates high capacity

Note: 1/2" ASFS housings have 1/8" Pharma Valve drain connection and 1/8" Pharma Plug Vent Connection

Note: 1"-3" ASFS housings have 1/4" Pharma Valve drain connection and 1/4" Pharma Plug Vent Connection



## Dimensions

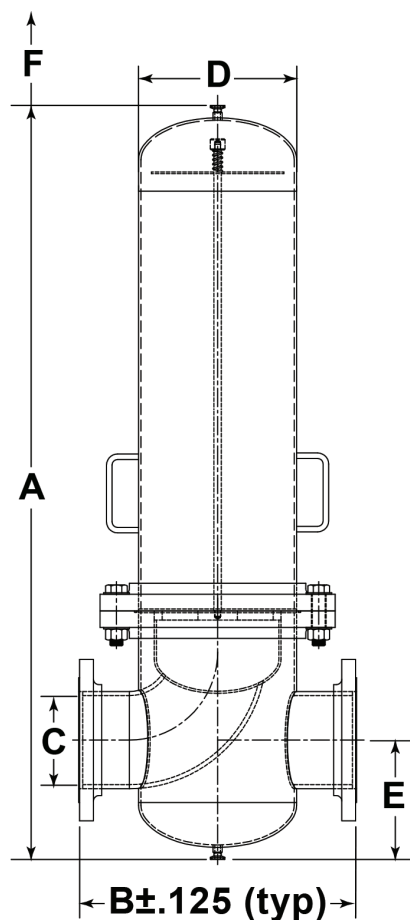

**Flange Connection ANSI Class 150**

Model Number	Connection Size (inch)	Volume (gal)	Weight* (lb)	Dimensions (inches)						Element Size
				A	B	∅C**	∅D	E	F	
ASF-HS 4 FW L***	4	9.5	95	38.0	16.14	4	8.6	7.3	23	3x20/30
ASF-HS 4 FW H***	4	11.9	97	48.8	16.14	4	8.6	7.3	33	3x30/30
ASF-HS 6 FW L***	6	20.3	154	51.5	18.90	6	10.8	8.12	33	4x30/30
ASF-HS 6 FW H***	6	29.1	176	55.7	21.26	6	12.8	9.3	33	6x30/30
ASF-HS 8 FW L***	8	50.2	298	59.5	25.98	8	16.0	12.8	33	8x30/30
ASF-HS 8 FW H***	8	50.2	298	59.7	25.98	8	16.0	12.8	33	10x30/30

\* Without filter element

\*\* ANSI B16.5 Class 150

\*\*\* L designates low capacity and H designates high capacity

Note: Vent and Drain are 1/2" Tri-Clamp connection

## Features & Benefits

- Thirteen sizes, three micron ratings, and connection options to meet virtually all purification requirements in steam filtration applications.
- High-quality continuous 316L sintered stainless steel filter media construction with 304 SS welded end caps ensures excellent material resistance to steam.
- Heavy-duty design withstands a maximum differential pressure up to 72 psi and an operating temperature range of -60°F to 392°F (with optional Fluoraz\* o-rings).
- The Sintered ASF 5 micron element exceeds 3-A guidelines for the production of Culinary Steam (95% @ 2 micron) under Accepted Practice T609-04.
- The 50+% porosity level ensures high dirt holding capacity at low differential pressure and high flow rate.
- Multiple regenerative methods are possible including back-flushing, ultrasonic cleaning, and solvent cleaning with hydrogen peroxide and other chemicals allowing for longer filter life and reduced operating costs.
- All components meet the FDA requirements for contact with food in accordance with the Code of Federal Regulations (CFR), Title 21. The filter element is manufactured according to DIN EN ISO 9001.

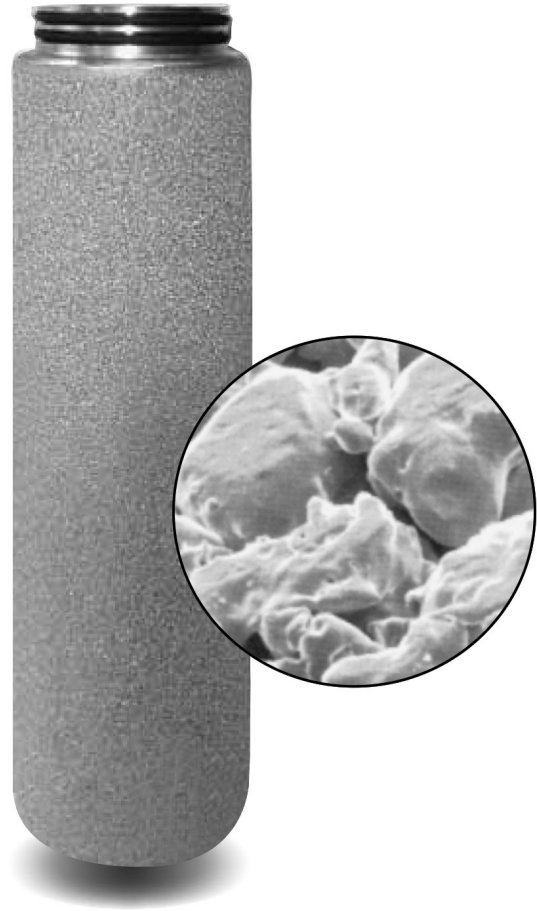

---

## Applications

There are several terms used for steam. Process steam is used in process applications as a source of energy for process heating, pressure control and mechanical drives. Culinary steam can be direct injected during food processing. Culinary steam needs to meet 3-A Culinary Standards for the dairy industry. Process steam does not generally come in contact with the final product whereas culinary steam can, and often does, come in direct contact with the final product.

### Steam Filtration

- Aseptic packaging
- Breweries
- Chemicals
- Dairies
- Electronics
- Food and beverage
- Pharmaceuticals
- Plastics

# Filter Elements - Sintered



## Product Specifications

Continuous Operating Temperature Range	-60°F to 356°F (EPDM 291 o-rings) -60°F to 392°F (Fluoraz® o-rings)
Configurations	Push-in 2" plug connection and flat end cap
Maximum Differential Pressure	72 psid, regardless of the system pressure or temperature
Element Pore Sizes	1, 5*, 25 micron
Typical Service Life	Total filter element life dependent on cleaning cycle frequency. Element replacement recommended after a maximum of 6 cleanings to prevent loss of integrity.

\* 5 micron elements exceed the 3A standard for culinary steam (95% @ 2 micron)

## Filtration Surface Area

Element Size	03/10	04/10	04/20	05/20	05/25	05/30	07/25	07/30	10/30	15/30	20/30	30/30	30/50
Surface Area (ft <sup>2</sup> )	.065	.092	.103	.135	.173	.248	.254	.367	.540	.837	1.13	1.77	3.18

## Materials

Filter Media	316L sintered stainless steel	CFR Title 211.65
End Caps	304 stainless steel	CFR Title 211.65
O-Rings Standard	EPDM 291	CFR Title 177.2600
O-Rings Optional	Fluoraz® (high temp)	CFR Title: 177.2600
	Silicone	CFR Title: 177.2600
	Buna N	CFR Title: 177.2600
	PTFE over silicone	CFR Title: 177.1550
	PTFE over Viton®*	CFR Title: 177.1550

\* Viton® is a registered trademark of DuPont Performance Elastomers L.L.C.

## Push-in Plug Connection

Dimensions (inches)					
Element Size	A	B	C (I.D.)*	C (O.D.)*	D
03/10	3.0	3.4	0.8	1.2	1.65
04/10	4.1	4.6	0.8	1.2	1.65
04/20	4.1	4.6	1	1.5	2.05
05/20	5.0	5.6	1	1.5	2.05
05/25	5.0	5.6	1	1.5	2.44
07/25	7.1	7.6	1	1.5	2.44
05/30	5.0	5.7	1	1.5	3.39
07/30	7.1	7.7	2	2.4	3.39
10/30	10.0	10.6	2	2.4	3.39
15/30	15.0	15.6	2	2.4	3.39
20/30	20.0	20.6	2	2.4	3.39
30/30	30.0	30.6	2	2.4	3.39
30/50	30.0	30.6	3.2	3.5	5.50

\* Plug-type connection with double o-ring

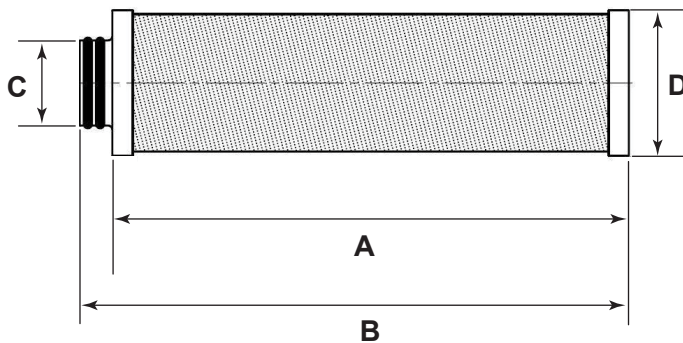

## Quality Assurance

All components of the Sintered ASF element with welded end caps are FDA listed for food contact use in the Code of Federal Regulations (CFR), Title 21.

All products have been inspected and released by Quality Assurance as having met the following requirements:

- All filter elements are fabricated without the use of binders, adhesives, additives or surface-active agents.
- All filter components based on plastics are non-toxic and are certified bio-safe in accordance with current USP Class VI Tests for Plastic.
- All filter elements are staged, assembled, tested, and packaged according to DIN EN ISO 9001.

## Higher Capacities And Longer Filter Life

Improved steam quality ensures increased efficiency of the entire process and longer service life of the filters to be sterilized. The Armstrong Pleated ASF is a regenerable, stainless steel filter element that captures contaminants such as particles, abrasion of valves and sealings, and rust. The Pleated ASF can be used in higher capacity applications where low pressure drop and reduced space are critical.

All components meet the USA requirements for Food Contact Use in accordance with the Code of Federal Regulations (CFR) Title 21, and the EU requirements for Food Contact Use according to EC/1935/2004. The filter element is manufactured in accordance with these manufacturing requirement, has no migration of filter media, and is non-fiber releasing.

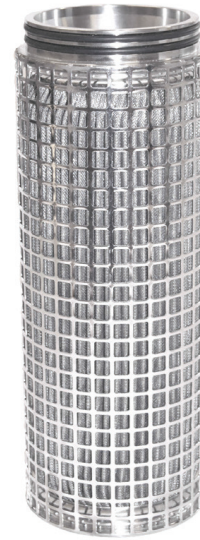

## Features & Benefits

- Filter down to 0.01µm in air/saturated steam
- Pleated, stainless steel media
- Low pressure drop
- Regenerable by back-flushing or ultrasonic cleaning
- Double O-ring
- Reduced operational risk with a 5µm element – users know that their steam meets the 3-A guidelines for culinary steam and approved for food contact use (according to CFR Title 21 and 1935/2004/EC)
- Higher dirt holding capacity at a low pressure drop
- Reduced operating costs allowing for energy savings
- Longer service life which leads to a lower cost of ownership

## Common Industries

- Processed Food
- Beverage
- Dairy
- Chemical
- Pharmaceutical
- Fermentation

## Material Compliance

All components of the Pleated ASF filter element are FDA listed for food contact use in the Code of Federal Regulations (CFR), Title 21. All products have been inspected and released by Quality Assurance as meeting the requirements. All filters are fabricated without the use of binders, adhesives, additives or surface-active agents.

Filter Matrix	304 Stainless Steel
Support	304 Stainless Steel
End Caps	304 Stainless Steel
O-rings	EDPM (alternate O-rings available upon request)

Filtration Surface	1.9 ft <sup>2</sup> per 10" element 10/30
Temperature Range	-68°F to 410°F >356°F special o-rings are required
Maximum Differential Pressure (Flow Direction = outside to inside)	145 psid, independent of the system pressure or temperature

## Specifications & Dimensions

Fraction Efficiency, 1µm, Air/Saturated Steam Fraction						
Efficiency [%]						
Pore Size (µm)	0.01 µm	0.07 µm	0.1 µm	0.2 µm	0.3 µm	0.4 µm
1	99.99	99.65	98.69	99.08	99.49	99.74

Push-in End Connection				
Filter Size	Dimensions (in)			Correction Factors**
	a	b	c*	
03/10	2.99	3.42	1.18	0.17
04/10	4.09	4.53	1.18	0.26
04/20	4.09	4.64	1.46	0.26
05/20	5.04	5.67	1.46	0.35
07/20	4.25	7.64	1.46	0.52
03/30	2.99	3.62	2.40	0.21
05/30	5.04	5.67	2.40	0.44
07/30	7.08	7.71	2.40	0.67
10/30	10	10.63	2.40	1.00
15/30	15	15.63	2.40	1.57
20/30	20	20.63	2.40	2.13
30/30	30	30.63	2.40	3.27
30/50	10	10.63	3.31	1.45

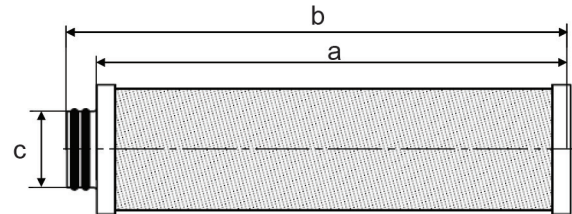

\* Plug-type connection with double o-ring  
 \*\* Correction factors filtration surface area

## Sizing & Selection Guidelines

Proper sizing and component selection of a steam filtration system is essential to ensuring that your application is operating as effectively and efficiently as possible. The following are some general guidelines, but additional sizing and selection tools are available to better optimize product selection to your specific needs.

### Housings

Armstrong Steam Filter (ASF) NPT housings in 304 SS are suitable for process steam filtration applications. In applications or installations where chemical corrosion is a concern, 316L SS as the material of construction is advisable.

For culinary steam, food contact and other sanitary applications the ASF Sanitary Grade, ASFS 3-A certified housing is used.

### Sintered Elements

The Armstrong Steam Filter (ASF) element is available in a number of different micron filtration ratings. For culinary steam applications, the 5 micron element exceeds the 3-A requirement of 2 micron at 95% efficiency. The micron rating selection for other applications will depend on the size of particles to be filtered and the purity requirements of the downstream process using the filtered steam.

## Regeneration/Cleaning

### Regeneration

Steam filter elements are commonly regenerated to reduce pressure drop, remove settled contaminants, and prevent permanent contamination buildup. The Armstrong Sintered ASF elements can be regenerated using a number of different techniques. In general, the more frequently an element is cleaned, the better the regeneration. It is recommended that all cleaners are in compliance with CFR, Title 21. The following is some general background in methods of steam filter element regeneration.

### Counter-Flow

The filter media can be washed with either clean liquid or clean gas in a reverse or counterflow cycle. Pulsing the flow to loosen attached particles can enhance cleaning. This method is excellent where retained particles are on the surface of the media. Use of a soft nylon brush can also enhance this method of cleaning.

### Clean Steam

In many applications, steam comes into contact with the product itself. For example, direct injection of steam into large vats of processed foods is one method used to cook those foods. In other cases, steam is used to clean or sterilize surfaces, tools and containers used in processing and packaging various products such as pharmaceuticals. In all cases, steam is being generated and distributed in piping systems, and these often end in small orifices or nozzles that can be easily fouled by contaminants in the steam.

Filtration of steam is essential to avoid product contamination and equipment downtime. Particulate contaminants found in steam can include rust, scale, dirt and sediments carried over from the water source.

### Sizing

Properly sizing a steam filter system will depend on a number of variables, which include:

- Flow rate (lbs/hr)
- Pressure and temperature
- Element micron rating
- Acceptable pressure drop across filtration system

### Solvent Cleaning Forward Flow

In some cases, oil and other contaminants in the steam cause particles to be retained on or within the filter media. Detergents and/or solvents might be required in these instances, not only to remove the oil or oil-like contaminants, but also to allow particles to be released. The chemical resistance of o-rings should be checked prior to solvent cleaning. After cleaning with solvents, it is essential to flush with cold water thoroughly and let all liquid evaporate.

### Ultrasonic Cleaning

The most thorough regeneration can be achieved using ultrasonic cleaning. In this method, filter elements are immersed in a non-flammable solvent or water bath in which ultrasonic waves lead to a loosening and removal of particles embedded in the media. Regeneration is nearly total, leaving elements close to their original state.



# Capacities for Steam

## Steam Flow Capacities<sup>1</sup> (lbs/hr)

304 SS Housings		Filter Element		Steam Pressure (psig)							
		Size	QTY	15	35	50	75	100	115	125*	150
FNPT Housings (also available in ANSI Flange)	ASF-H4 1/4	03/10	1	46	77	100	139	177	200	215	253
	ASF-H4 3/8	04/10	1	69	116	150	209	266	300	323	380
	ASF-H4 1/2	04/20	1	81	135	175	243	310	350	376	443
	ASF-H4 3/4	05/20	1	104	173	225	313	398	450	484	569
	ASF-H4 1	05/25	1	138	231	300	417	531	600	645	759
	ASF-H4 1-1/4	07/25	1	198	331	430	598	761	860	925	1088
	ASF-H4 1-1/2	07/30	1	281	470	610	848	1080	1220	1312	1543
	ASF-H4 2 L**	10/30	1	368	616	800	1112	1416	1600	1720	2024
	ASF-H4 2 H**	15/30	1	495	828	1075	1494	1903	2150	2311	2720
	ASF-H4 2-1/2	20/30	1	759	1271	1650	2294	2921	3300	3548	4175
	ASF-H4 3 L**	30/30	1	943	1579	2050	2850	3629	4100	4408	5187
ASF-H4 3 H**	30/50	1	1164	1948	2530	3517	4478	5060	5440	6401	
ANSI Flanged Housings	ASF-H4 4 L**	20/30	3	2070	3465	4500	6255	7965	9000	9675	11385
	ASF-H4 4 H**	30/30	3	2691	4505	5850	8132	10355	11700	12578	14801
	ASF-H4 6 L**	30/30	4	4232	7084	9200	12788	16284	18400	19780	23276
	ASF-H4 6 H**	30/30	6	5520	9240	12000	16680	21240	24000	25800	30360
	ASF-H4 8 L**	30/30	8	6854	11473	14900	20711	26373	29800	32035	37697
	ASF-H4 8 H**	30/30	10	7866	13167	17100	23769	30267	34200	36765	43263

316L SS Sanitary Housings		Filter Element		Steam Pressure (psig)							
		Size	QTY	15	35	50	75	100	115	125*	150
Tri-Clamp Housings, 3-A Certified	ASF-HS 1/2 L**	03/10	1	46	77	100	139	177	200	215	253
	ASF-HS 1/2 H**	05/20	1	74	123	160	222	283	320	344	405
	ASF-HS 1	05/30	1	184	308	400	556	708	800	860	1012
	ASF-HS 2	10/30	1	368	616	800	1112	1416	1600	1720	2024
	ASF-HS 2-1/2	20/30	1	828	1386	1800	2502	3186	3600	3870	4554
	ASF-HS 3	30/30	1	1150	1925	2500	3475	4425	5000	5375	6325
ANSI Flanged Housings <sup>2</sup>	ASF-HS 4 L**	20/30	3	2070	3465	4500	6255	7965	9000	9675	11385
	ASF-HS 4 H**	30/30	3	2691	4505	5850	8132	10355	11700	12578	14801
	ASF-HS 6 L**	30/30	4	4232	7084	9200	12788	16284	18400	19780	23276
	ASF-HS 6 H**	30/30	6	5520	9240	12000	16680	21240	24000	25800	30360
	ASF-HS 8 L**	30/30	8	6854	11473	14900	20711	26373	29800	32035	37697
	ASF-HS 8 H**	30/30	10	7866	13167	17100	23769	30267	34200	36765	43263

1. Published capacity based on 5 micron sintered filter element and 2 psig pressure drop. Capacities are general recommendations and may vary based on element selections, operating conditions and allowable pressure losses. Consult factory for different filtration capacities.
2. All 4" - 8" ANSI flange housing are designed and built to ASME code and are stamped accordingly. The ANSI flange housings are not 3-A Certified.
3. Consult factory for capacities of pleated filter elements.

\* For steam pressures greater than 125 psig, it is recommended to use Fluoraz® gaskets and o-rings

\*\* L designates low capacity and H designates high capacity

Designs, materials, weights and performance ratings are approximate and subject to change without notice. Visit [armstronginternational.com](http://armstronginternational.com) for up-to-date information.



## Limited Warranty and Remedy

Armstrong International, Inc. or the Armstrong division that sold the product (“Armstrong”) warrants to the original user of those products supplied by it and used in the service and in the manner for which they are intended, that such products shall be free from defects in material and workmanship for a period of one (1) year from the date of installation, but not longer than 15 months from the date of shipment from the factory, [unless a Special Warranty Period applies, as listed below]. This warranty does not extend to any product that has been subject to misuse, neglect or alteration after shipment from the Armstrong factory. Except as may be expressly provided in a written agreement between Armstrong and the user, which is signed by both parties, Armstrong **DOES NOT MAKE ANY OTHER REPRESENTATIONS OR WARRANTIES, EXPRESS OR IMPLIED, INCLUDING, BUT NOT LIMITED TO, ANY IMPLIED WARRANTY OF MERCHANTABILITY OR ANY IMPLIED WARRANTY OF FITNESS FOR A PARTICULAR PURPOSE.**

The sole and exclusive remedy with respect to the above limited warranty or with respect to any other claim relating to the products or to defects or any condition or use of the products supplied by Armstrong, however caused, and whether such claim is based upon warranty, contract, negligence, strict liability, or any other basis or theory, is limited to Armstrong’s repair or replacement of the part or product, excluding any labor or any other cost to remove or install said part or product, or at Armstrong’s option, to repayment of the purchase price. As a condition of enforcing any rights or remedies relating to Armstrong products, notice of any warranty or other claim relating to the products must be given in writing to Armstrong: (i) within 30 days of last day of the applicable warranty period, or (ii) within 30 days of the date of the manifestation of the condition or occurrence giving rise to the claim, whichever is earlier. **IN NO EVENT SHALL ARMSTRONG BE LIABLE FOR SPECIAL, DIRECT, INDIRECT, INCIDENTAL OR CONSEQUENTIAL DAMAGES, INCLUDING, BUT NOT LIMITED TO, LOSS OF USE OR PROFITS OR INTERRUPTION OF BUSINESS.** The Limited Warranty and Remedy terms herein apply notwithstanding any contrary terms in any purchase order or form submitted or issued by any user, purchaser, or third party and all such contrary terms shall be deemed rejected by Armstrong.







INTELLIGENT SOLUTIONS IN STEAM, AIR AND HOT WATER

**Armstrong International**

North America • Latin America • India • Europe / Middle East / Africa • China • Pacific Rim

[armstronginternational.com](http://armstronginternational.com)