

TV-2 Thermostatic Air Vent

For Pressures to 9 bar...Capacities to 78 m³/h

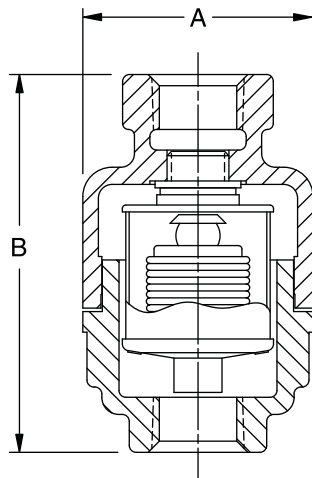

**TV-2
Thermostatic Air Vent**



Armstrong offers the Model TV-2 Balanced Pressure Thermostatic Air Vent for positive venting of air from chamber type heat transfer equipment with no loss of steam. Typical applications include jacketed kettles, retorts, vulcanizers, jacketed sterilizers or other contained equipment where air could accumulate at the top of the steam chamber and reduce heat transfer capacity.

The Model TV-2 is a balanced-pressure thermostatic air vent that responds to the pressure-temperature curve of steam at any pressure from light vacuum to maximum operating pressure. Air is automatically vented at slightly below steam temperature throughout the entire operating pressure range.

The thermostatic element is a charged multi-convolution phosphor bronze bellows caged in stainless steel. Valve and seat are also stainless steel designed to meet the most rigid cycling specifications known for this type of service.

Features

- Stainless steel hemispherical valve and seat
- Thermostatic element comprises a multi-convolution phosphor bronze bellows caged in stainless steel
- Thermostatic element is charged with water to provide positive opening of the valve at slightly below steam temperature and positive closing in the presence of steam throughout the operating pressure range
- ASTM B62 cast bronze body

Armstrong Model TV-2 Thermostatic Air Vents should be installed at the highest points of steam chambers with inlet connections to the vents higher than the highest points of the chambers. Thus installed there is a minimum hazard of any liquid carryover and air can be vented to atmosphere with no drain line necessary.

Pipe Connections	mm
	15
"A" (Diameter)	56
"B" (Height)	89
Weight in kg (screwed)	0,8
Maximum Operating Pressure	9 bar
Maximum Temperature	177°C

Name of Part	Material
Body & Cap	Cast bronze ASTM B62
Gasket	Compressed non-asbestos
Thermostatic Unit	
Bellows	Phosphor bronze
Cage and Cover	Stainless steel
Thermostatic Unit Gasket	Copper clad

All sizes comply with the article 3.3 of the PED (97/23/EC).

All dimensions and weights are approximate. Use certified print for exact dimensions. Design and materials are subject to change without notice.