

Washdown Equipment

047-79 Compact Hose Reel

Red Spring Retractable Hose Reel for use with all Armstrong Hose Station assemblies. Guide arm is field adjustable for wall, floor or ceiling mounting. Compact hose reel capable of holding up to 25' (7.6 m) of 3/4" (20 mm) Washdown Hose*. Includes adjustable hose bumper stop to maintain desired length of hose outside reel and 4' (1.2 m) flexible adapter hose from hose reel to hose station.



For fully detailed certified drawing, contact Armstrong.

047-81 Compact Hose Reel

Red Spring Retractable Hose Reel for use with all Armstrong Hose Station assemblies. Dual pedestal base provides extra strength. Guide arm is field adjustable for wall, floor or ceiling mounting. Compact hose reel capable of holding up to 50' (15.2 m) of 3/4" (20 mm) Washdown hose*. Includes adjustable hose bumper stop to maintain desired length of hose outside of reel and 4' (1.2 m) flexible adapter hose from hose reel to hose station.



047-81SS Compact, Stainless Steel Hose Reel

As above, in stainless steel for applications requiring maximum corrosion resistance.

For fully detailed certified drawing, refer to CDLW #1026.



047-82 Hose Reel

Red Spring Retractable Hose Reel for use with all Armstrong Hose Station assemblies. Wider dual pedestal base provides maximum strength. Guide arm is field adjustable for wall, floor or ceiling mounting. Compact hose reel capable of holding up to 75' (22.8 m) of 3/4" (20 mm) Washdown Hose*. Includes adjustable hose bumper stop to maintain desired length of hose outside of reel and 4' (1.2 m) flexible adapter hose from hose reel to hose station.



The 047-82 supersedes the 047-1.

047-82SS Stainless Steel Hose Reel

As above, in stainless steel for applications requiring maximum corrosion resistance.

The 047-82SS supersedes the 047-SS.

For fully detailed certified drawing, refer to CDLW #1026.



*Hose and spray nozzle supplied separately.

Hose Reel Benefits

- Helps to eliminate the danger of tangled hose, reducing safety hazards.
- Cleans up work area while improving efficiency by reducing the amount of time spent handling the hose. Also provides improved utilization of available space.
- Hose stored on a reel is protected from damage and unnecessary wear and tear, greatly extending hose life.
- Helps keep hose out of the way when not in use, yet conveniently within reach when needed
- Improves work environment.

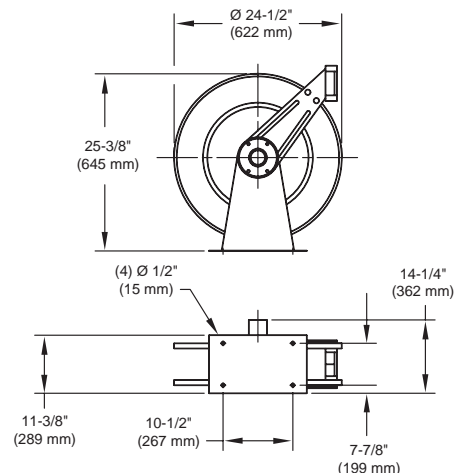
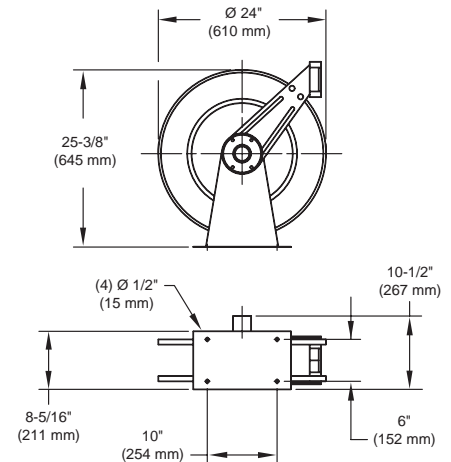

All dimensions and weights are approximate. Use certified print for exact dimensions. Design and materials are subject to change without notice.