



# Hot Water Generation – Steam/Water Single Wall

## Digital-Flo® Semi-Instantaneous Steam/Water Shell and Tube Heat Exchanger

### Model DFS3540

DFS3540 is a complete pre-piped single wall semi-instantaneous steam/water shell and tube heater. The assembly includes a properly sized shell and tube heat exchanger with a Digital Recirculating Valve (DRV40).

Digital technology provides enhanced water temperature control accuracy and enhanced user safety in a single control component.

### Operational Specifications

- +/-2°F water temperature control at points of use 25' downstream during demand
- +/-2°F water temperature control during zero system demand
- "idling" periods
- 2°F minimum valve inlet to outlet temperature requirement (system recirculation temperature loss)
- Automatic shutoff of hot water flow upon cold water inlet supply failure
- Automatic shutoff of hot water flow in the event of a power failure
- Programmable set point range of 81-158°F (27-70°C)
- Programmable 1st level hi/lo temp alarm display
- Programmable temperature error level for double safety shutdown.

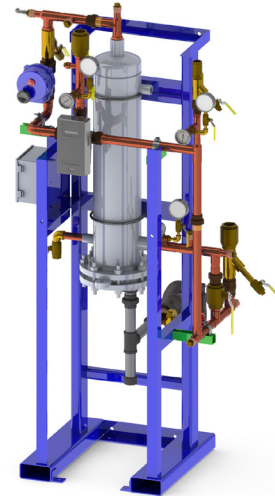

### Technical Specifications

- Maximum steam pressure: 15 PSIG constant.
- Maximum domestic pressure: 150 PSI
- Minimum recirculation flow: 5 GPM
- Design conditions: Domestic-28 GPM at 100°F delta T using 15 PSIG steam; 35 GPM at 120 °F Setpoint using Blend Formula
- Complete assembly Lead Free Compliant
- All domestic side valve fittings and isolation valves, strainers, inlet/return check valves, inlet system blend and return thermometers pre-piped.
- DRV – all wetted parts 316 stainless steel
- DRV to be UL Listed
- Heat exchanger shall be U-bend 3/4" copper tubes expanded into 304 stainless steel tube sheets
- Water pipe of type L copper
- Fabricated carbon steel frame with machine grade enamel paint
- 120 volt power supply required
- Secondary (double) safety shut-off valve included
- SAGE™ enabled

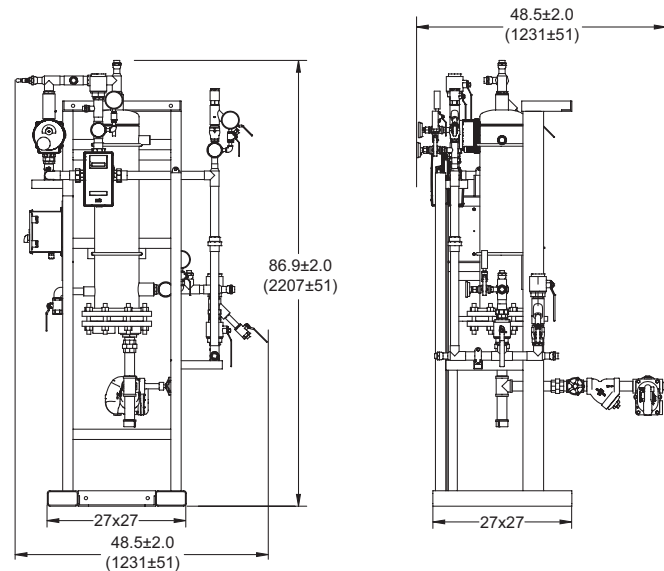

### Connectivity

**SPCO Relay Outputs** – Relay which is energized during operation.

**LCD Display** – Provides information on set point, delivered temperature, error messages and alert conditions.

**RS485 Serial Port** – Connects the DRV to either Modbus® RTU or SAGE™. (See DFS1540BS for package with SAGE™.)

**Modbus® RTU** – DRV can be configured to communicate directly with Building Automation Systems (BAS) using Modbus® RTU protocol.

Designs, materials, weights and performance ratings are approximate and subject to change without notice. Visit [armstronginternational.com](http://armstronginternational.com) for up-to-date information.