



EPT-516 High Capacity Pumping Trap

Carbon Steel, In-Line Connections

For capacities up to 35 920 kg/h (steam motive)... Discharge per cycle 475 liters

Condensate Recovery Equipment



Effective recovery and return of hot condensate are essential to overall plant efficiency while conserving energy. Large amounts of condensate provide the best opportunities to save energy.

The Armstrong EPT-516 High Capacity Pumping Trap is the low maintenance, non-electric solution to moving large amounts of condensate and other liquids from low points, low pressures or vacuum spaces to an area of higher elevation or pressure. Condensate can be returned at temperatures well above the 99°C limit of conventional electric pumps without the headaches of leaking seals or cavitation.

Features

- Non-electric – Uses inexpensive steam, air or gas to operate the pump trap
- No leaking seals/packings, impeller wear, electrical or motor problems – Reduces maintenance and downtime
- Single trade installation or repair reduces installation and maintenance costs
- Direct spring/float actuated mechanism – No maintenance intensive diaphragm operated valve mechanism
- Compression spring design – Reduces downtime, ensures performance and reliability
- Rugged stainless steel internals – Durable and corrosion resistant for enhanced service life
- Closed loop – No motive steam or flash steam loss, therefore capturing and returning all valuable kJ back to the system (see General Applications on page CRE-216)
- Safety – Pump can be placed in flooded pits without fear of electrocution or circuit breaker defaults
- Explosion proof – Standard unit intrinsically safe without additional cost

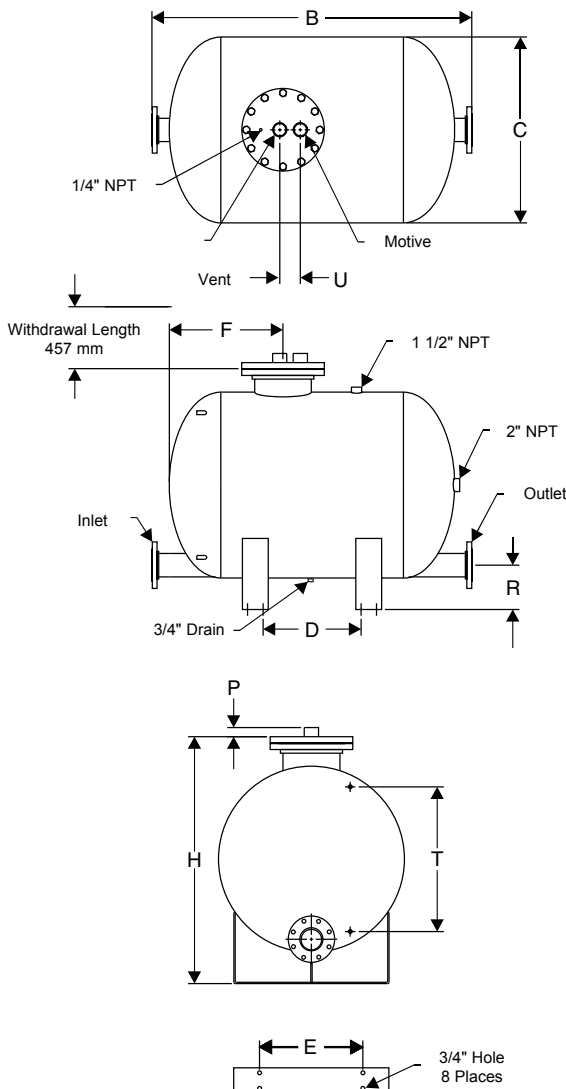

Table CRE-228-1. EPT-516 Pumping Trap Physical Data

	mm
Inlet Connection	4" 150# ANSI Fig. - DN100 PN40
Outlet Connection	4" 150# ANSI Fig. - DN100 PN40
Motive Connection	2" NPT
Vent Connection	2" NPT
Gauge Glass Connection	1/2" NPT
«B»	1 574
«C»	914
«D»	484
«E»	508
«F»	559
«H»	1 219
«P»	44
«R»	222
«T»	711
«U»	100
Weight	366
Number of Bolts	12

Maximum Operating Pressure on standard unit: 10 barg.

For higher pressure, please consult factory.

Maximum Allowable Pressure (standard vessel design): 10 barg @ 250°C.

21 barg vessel available upon request.

This model is CE Marked according to the PED (97/23/EC).

All dimensions and weights are approximate. Use certified print for exact dimensions. Design and materials are subject to change without notice.

Armstrong International SA • Parc Industriel des Hauts-Sarts (2^e Avenue) • 4040 Herstal • Belgium

Tel.: +32 (0)4 240 90 90 • Fax: +32 (0)4 240 40 33

www.armstronginternational.eu • info@armstronginternational.eu

EPT-516 High Capacity Pumping Trap

Carbon Steel, In-Line Connections

For capacities up to 35 920 kg/h (steam motive)... Discharge per cycle 475 liters



Typical Applications

- Low pressure heating systems
- Process heat exchanger or coils with modulating steam control
- Remote installations (tracing, tank farms or remote coils)
- Systems under vacuum
- Hazardous (explosion proof) areas
- Caustic environments
- Sumps or submersed areas

Table CRE-229-1. EPT-516 Pumping Trap Materials

Name of Part	Description
Cap, Body, Bolting	Fabricated Carbon Steel ASME VIII division I - ASTM A106 GrB / ASTM A516 Gr60 / ASTM A105
Cap Gasket	Compressed Non-Asbestos
Inlet Valve Assembly	Stainless Steel
Vent Valve Assembly	Stainless Steel
Mechanism Assembly: Frame, Float & Spring	Stainless Steel

Notes: 21 bar ASME vessel available upon request. EPT-516 available in all stainless steel. Consult factory.

Armstrong EPT-516 Pump Trap Sizing and Selection

Table CRE-229-2. EPT-516 Pumping Trap Capacities (600 mm Filling Head)

Motive Pressure	Total Lift or Back Pressure	EPT-516	
		4" x 4"	
		Steam	Air
bar	bar	kg/h	kg/h
1,0	0,35	13 150	26 160
		16 870	28 110
		21 925	30 750
		24 890	32 300
		26 975	33 400
		29 930	On request
1,7	1,0	16 670	23 055
		20 520	26 338
		23 180	28 258
		25 275	29 620
		28 570	On request
2,5	1,5	13 260	20 990
		15 170	23 140
		17 500	25 575
		19 275	27 305
		21 965	On request
3,5	3,0	11 900	18 725
		12 420	19 990
		13 055	21 535
		13 870	23 530
		15 025	On request
4,5	4,0	11 790	14 540
		11 975	15 215
		12 730	18 590
		13 800	On request
7,0	5,5	10 837	15 827
		10 991	On request
		11 145	On request

Notes: Above capacities are the results of actual steam testing using a minimum 93°C condensate. Published capacities are based on the use of external check valves supplied by Armstrong. Discharge per cycle: 475 liters.

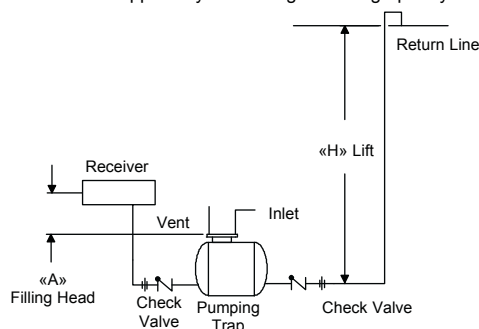

Table CRE-229-3. EPT-516 Capacity Conversion Factors for Other Fill Heads

Model	Filling Head (mm)					
	0	150	300	400	600	900
EPT-516	0,7	0,75	0,8	0,85	1,0	1,08

Note: Filling head is measured from drain of receiver to top of pump's cap.

Options

- Gauge Glass Assembly with Guards (Brass or Carbon Steel, Cadmium Plated)
- Digital Cycle Counter (Open or Closed Systems; with or without Auxiliary contacts)
- Insulation Jacket

This pump might be suitable for special applications. Please consult factory

Application Data

1. Fluid to be pumped:
2. Temperature of fluid to be pumped: °C
3. Specific gravity:
4. Required flow rate: m³/h □ kg/h
5. Equipment pressure: Modulation
Min. to Max.....
□ bar
6. Fill head distance (A): mm
7. Discharge condensate return line size: mm
8. Motive gas: □ Steam □ Air □ Gas
9. Motive pressure available: □ bar □ Other.....
10. Return line pressure: □ bar □ Other.....
11. Vertical lift (H): m
12. Can pump be vented to atmosphere? □ Yes □ No
13. Is there a condensate reservoir? □ Yes □ No
If yes, what size?.....
14. Is reservoir vented? □ Yes □ No
15. Would you like Armstrong to quote on a packaged piped engineered system? □ Yes □ No