



ICS Series Float and Thermostatic Steam Trap

Carbon Steel with Integral Flanges for Horizontal or Vertical Installation with Thermostatic Air Vent
For pressures to 32 bar ... Capacities to 27 215 kg/h

Description

Armstrong ICS Series F&T traps are for industrial service from 0 to 32 bar. The simple yet rugged construction of the ICS series carbon steel float and thermostatic trap is designed to assure long, trouble-free service. A full range in flanged connection sizes is offered: 1/2" through 2".

Materials

Body and Cap: ASTM A352 Gr. LCB
Internals: Stainless Steel
Valve and Seat: Stainless Steel
Thermostatic Air Vent: Wafer type stainless steel with hastelloy element

Connections

Flanged ASME B16.5 Class 150 - 300
EN1092-1 PN40

Socketweld
NPT / BSPT

Options

Integral vacuum breaker. Add suffix VB to model number (PMA:10 barg@184 °C)
Condensate controller. Add suffix CC to model number.

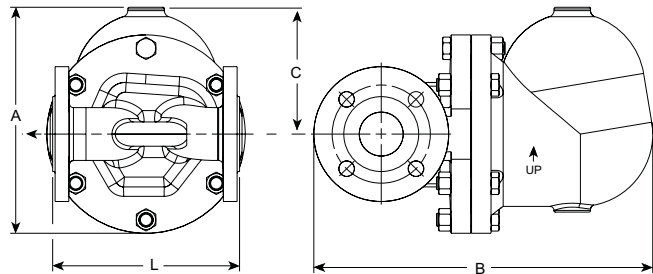

Table 140-1. Flow Direction

	mm	Flow Direction
Horizontal	15, 20, 25	Left-to-Right
Horizontal	40, 50	Right-to-Left
Vertical*	All	Down

* For vertical applications and dimensions, please consult factory.

Table 140-2. Face-to-Face Dimensions - NPT / BSPT / Socketweld

Connection Size	mm	mm	mm	mm	mm
	15	20	25	40	50
A	196	196	211	288	288
B	278	279	314	374	380
C	126	126	131	166	166
L	184	178	188	266	273
Weight, kg	10	10	13	35	35
Maximum Allowable Pressure (Vessel Design)	40 barg @ 343 °C				
Maximum Operating Pressure	32 barg				

Table 140-3. Face-to-Face Dimensions - ASME B 16.5 Class 150#

Connection Size	mm	mm	mm	mm	mm
	15	20	25	40	50
A	196	196	211	288	288
B	301	306	344	399	412
C	126	126	131	166	166
L	203	205	208	321	312
Weight, kg	11	11	15	38	38
Maximum Allowable Pressure (Vessel Design) †	13,6 barg @ 205 °C				
Maximum Operating Pressure	13,6 barg				

Table 140-4. Face-to-Face Dimensions - PN40

Connection Size	mm	mm	mm	mm	mm
	15	20	25	40	50
A	196	196	211	288	288
B	304	309	347	413	420
C	126	126	131	166	166
L	150	150	160	230	230
Weight, kg	11	12	20	36	40
Maximum Allowable Pressure (Vessel Design) †	34,4 barg @ 250 °C				
Maximum Operating Pressure	32 barg				

Table 140-5. Face-to-Face Dimensions - ASME B 16.5 Class 300#

Connection Size	mm	mm	mm	mm	mm
	15	20	25	40	50
A	196	196	211	288	288
B	304	314	352	414	419
C	126	126	131	166	166
L	209	209	212	327	321
Weight, kg	11	12	16	40	40
Maximum Allowable Pressure (Vessel Design) †	40,4 barg @ 260 °C				
Maximum Operating Pressure	32 barg				

Note: Shade indicates products that are CE Marked according to the PED (97/23/EC). All other models comply with the Article 3.3 of the same directive.

† May be derated depending on flange rating and type.

All dimensions and weights are approximate. Use certified print for exact dimensions. Design and materials are subject to change without notice.

Armstrong International SA • Parc Industriel des Hauts-Sarts (2^e Avenue) • 4040 Herstal • Belgium

Tel.: +32 (0)4 240 90 90 • Fax: +32 (0)4 240 40 33

www.armstronginternational.eu • info@armstronginternational.eu

ICS Series Float and Thermostatic Steam Trap

Carbon Steel with Integral Flanges for Horizontal or Vertical Installation with Thermostatic Air Vent
For pressures to 32 bar ... Capacities to 27 215 kg/h



Table 141-1. Model ICS Series Capacity 1/2" and 3/4" - DN15 and DN20

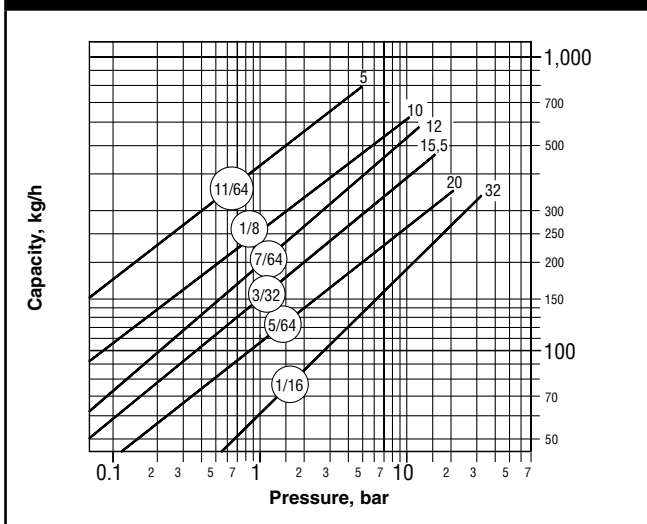

Table 141-2. Model ICS Series Capacity 1" - DN25

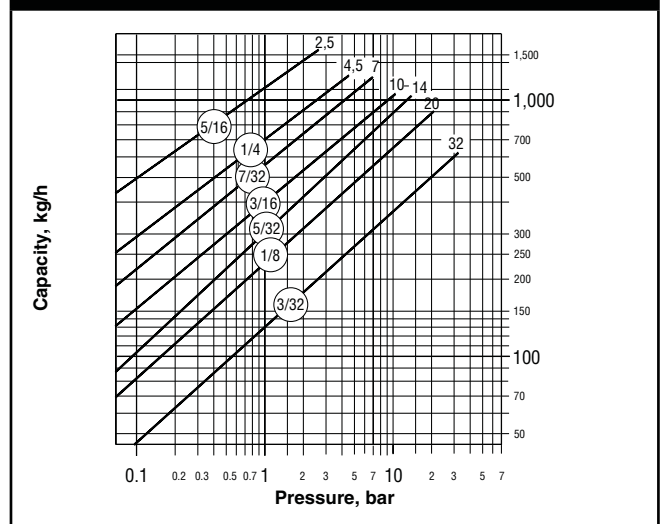

Table 141-3. Model ICS Series Capacity 1-1/2" - DN40

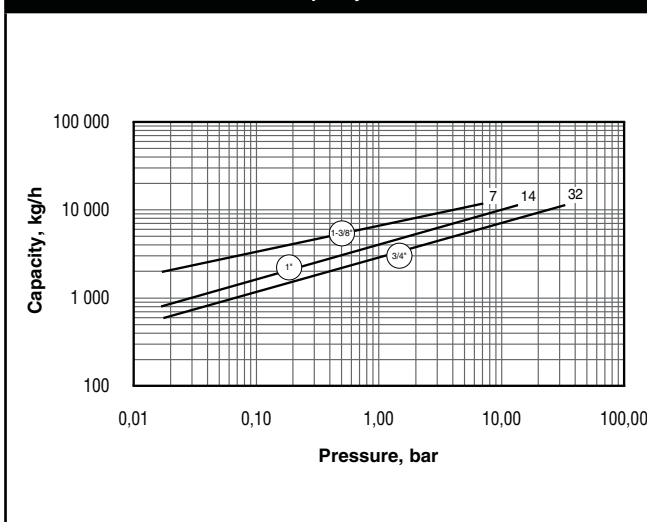
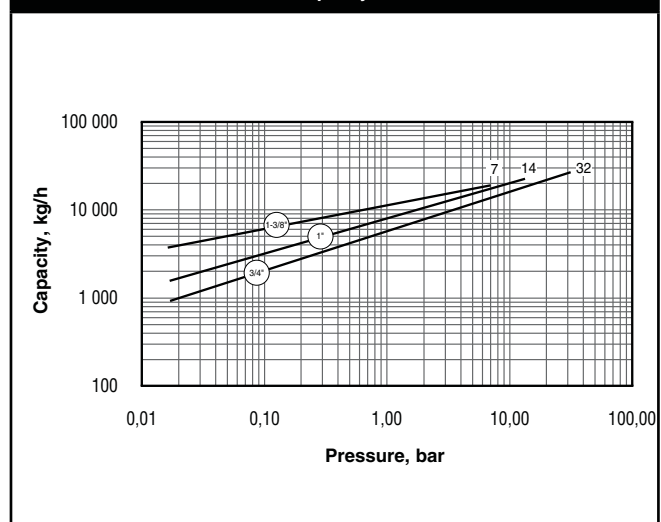

Table 141-4. Model ICS Series Capacity 2" - DN50



Note: PMA/TMA are limited according to the flange selected on the trap model.

Table 141-5. Models with flanges - Limitations

Flange Type	PMA/TMA	Orifice available (depending on connection size)	
		Connection	Available Orifice
ASME B16.5 Class 150	13,8 barg @ 200 °C	15 - 20	11/64 - 1/8 - 7/64
		25	5/16 - 1/4 - 7/32 - 3/16 - 5/32
		40 - 50	1-3/8 - 1
ASME B16.5 Class 300	40,8 barg @ 250 °C	15 - 20 - 25 - 40 - 50	all orifices available consult charts
PN40	35,1 barg @ 250 °C	15 - 20 - 25 - 40 - 50	all orifices available consult charts

How to Order

Model	Flow Direction	Connection Size	Connection Type	Pressure	Option
ICS F+T	R/L	DN50	PN40	1-3/8"	VB
ICS F+T	L/R = Left to Right or Vertical	1/2"/DN15 3/4"/DN20 1"/DN25	Flanged Connection or Socketwelded or NPT or BSPT	Consult Capacity Charts to specify orifice.	VB = Vacuum Breaker (limited to 10 bar)
	R/L = Right to Left or Vertical	1-1/2"/DN40 2"/DN50			

All dimensions and weights are approximate. Use certified print for exact dimensions. Design and materials are subject to change without notice.